

NP12-12Ah 12V12Ah

Specifications

Nominal Voltage		12V
Rated capacity (20 hour rate)		12Ah
Dimensions	Length	151±1.5mm(5.94inch)
	Width	98±1mm(3.86inch)
	Height	95±1mm(3.74inch)
	Total Height	101±1mm(3.98inch)
Approx. Weight		3.4kg(7.5lbs)±4%



Outer dimensions (mm)

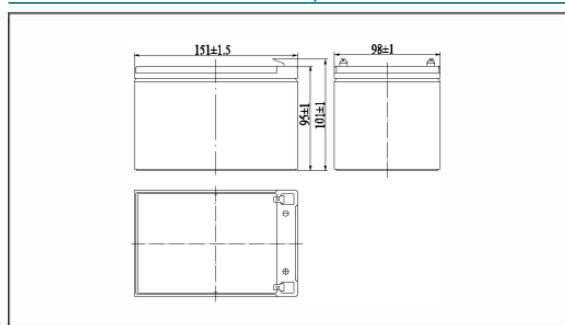

Terminal Type (mm)

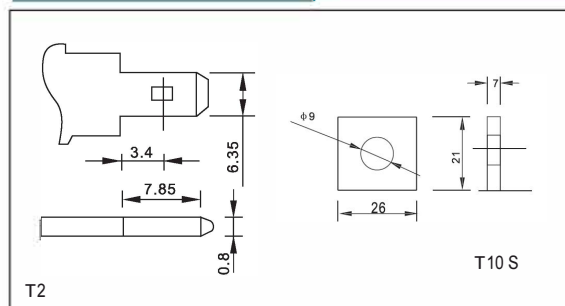

Characteristics

Capacity (25°C)	20HR(10.5V)	12Ah
	10HR(10.5V)	11Ah
	1HR(9.60V)	7.2Ah
Terminal type		T2/T10 S
Internal resistance (Fully charged,25°C)		Approx.19m Ω
Capacity affected by temperature (20HR)	40°C	102%
	25°C	100%
	0°C	85%
	-15°C	65%
Self-discharge (25°C)	3 months	Remaining Capacity:91%
	6 months	Remaining Capacity:82%
	12 months	Remaining Capacity:65%
Nominal operating temperature		25°C ± 3°C(77°F ± 5°F)
Operating temperature range	Discharge	-15°C~50°C(5°F~122°F)
	Charge	-10°C~50°C(14°F~122°F)
	Storage	-20°C~50°C(-4°F~122°F)
Float charging voltage(25°C)		13.50 to 13.80V Temperature compensation: -18mV/°C
Cyclic charging voltage(25°C)		14.50 to 15.00V Temperature compensation: -30mV/°C
Maximum charging current		3.6A
Maximum discharge current		180A(5 sec.)
Designed floating life(20°C)		5 years

Construction

Component	Positive plate	Negative plate	Container	Cover	Separator	Electrolyte	Safety valve	Terminal
Raw material	Lead dioxide	Lead	ABS	ABS	AGM	Sulfuric acid	Rubber	Copper

Constant Current Discharge Characteristics Unit:A(25°C,77°F)

F.V/Time	5min	10min	15min	30min	60min	2h	3h	4h	5h	10h	20h
9.60V	45.8	29.0	22.7	12.8	7.86	4.3	2.97	2.46	2.09	1.14	0.61
9.90V	44.5	28.2	22.1	12.5	7.74	4.27	2.96	2.45	2.08	1.13	0.61
10.2V	42.6	27.0	21.3	12.1	7.55	4.24	2.94	2.43	2.07	1.13	0.60
10.5V	40.8	25.8	20.6	11.8	7.40	4.17	2.92	2.41	2.05	1.12	0.60
10.8V	38.5	24.4	19.5	11.4	7.17	4.07	2.83	2.34	1.99	1.10	0.59

Constant Power Discharge Characteristics Unit:W(25°C,77°F)

F.V/Time	5min	10min	15min	30min	60min	2h	3h	4h	5h	10h	20h
9.60V	512	328	259	146	91.0	50.3	35.3	29.3	25.0	13.6	7.31
9.90V	496	318	252	144	89.7	50.0	35.1	29.1	24.8	13.6	7.28
10.2V	476	305	243	139	87.4	49.6	34.9	28.9	24.7	13.5	7.24
10.5V	455	292	235	136	85.6	48.8	34.6	28.7	24.5	13.4	7.20
10.8V	430	275	222	131	83.0	47.6	33.6	27.9	23.8	13.2	7.06

Note: The above characteristics data can be obtained within three charge or discharge cycles.

NP12-12Ah 12V12Ah

● **Discharge characteristics(25°C)**

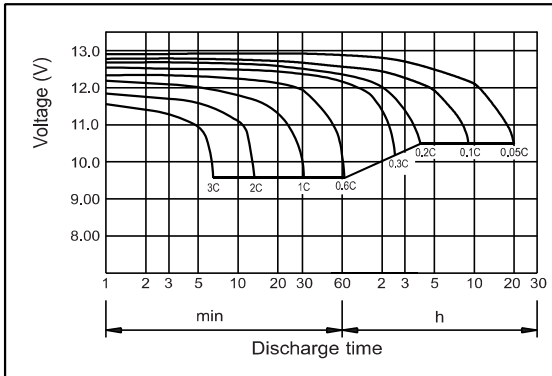

● **Charging characteristics (25°C)**

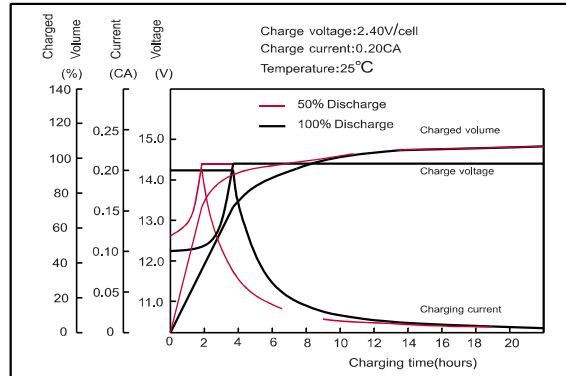

● **Effect of temperature on capacity**

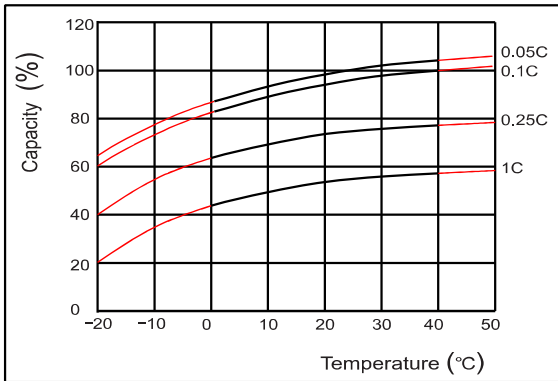

● **Self-discharge characteristics**

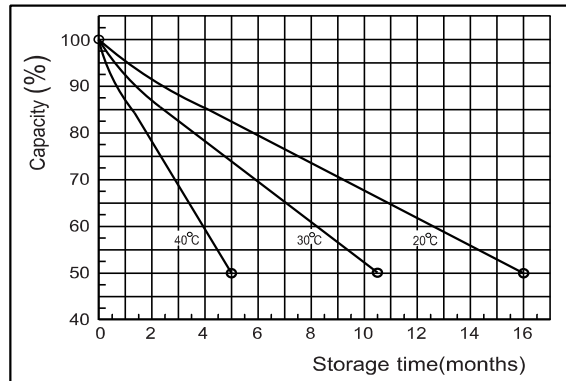

● **Floating life on temperature**

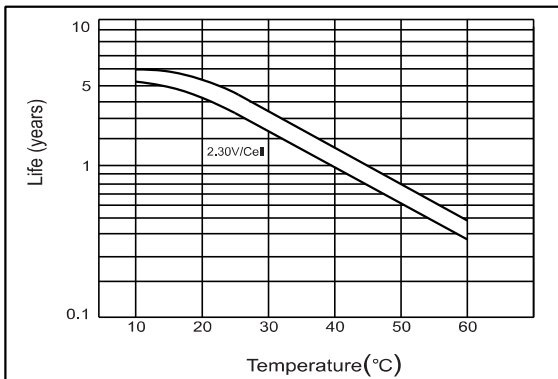

● **Cycle life on D.O.D(25°C)**

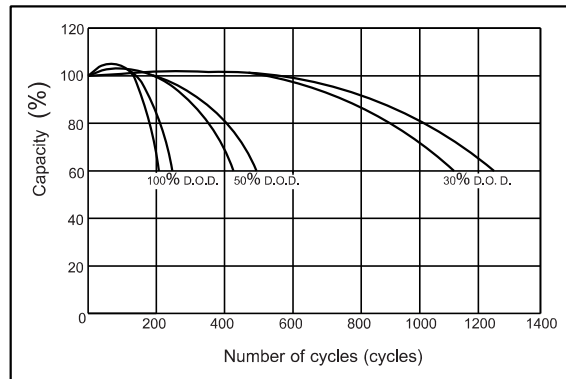

● **The relationship for OCV and Capacity (25°C)**

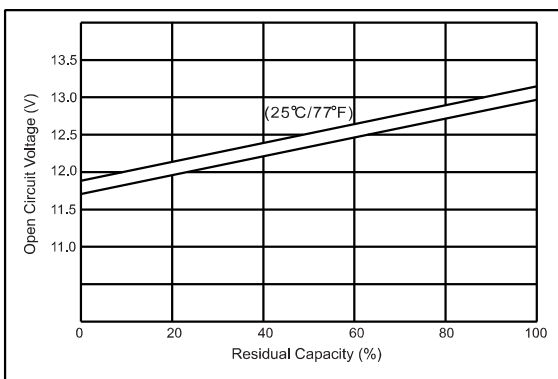

● **The relationship for Charging voltage and Temperature**

